

LEVER HANDLES

INSTALLATION INSTRUCTIONS

PASSAGE 51MM HOLE



Regularly clean handles using a microfibre cloth and warm water.



Avoid using abrasive cleaners, as they can damage the product's coating.

Installation Cut-Out Guide

Please note:

1. Diagram is not to scale
2. This lever will fit 32mm to 45mm door thicknesses
3. Handle height recommended is 900-1000mm from floor to center of drill hole

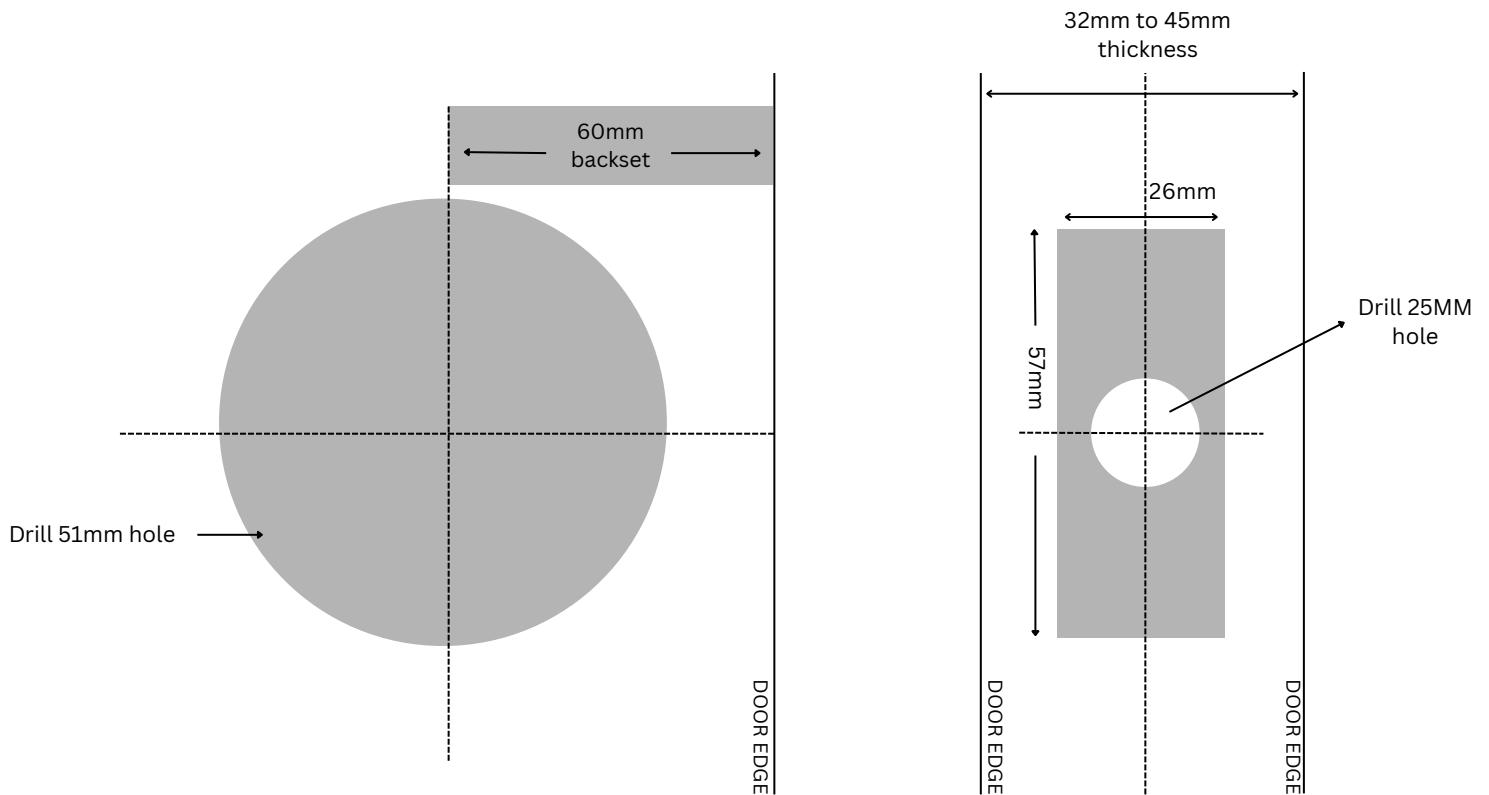

Disclaimer:

This handle must be installed by a licensed and qualified tradesperson. Improper installation may result in damage to the product or surrounding materials and may affect functionality.

Please note that various factors—including door type, thickness, alignment, environmental conditions, and compatibility with existing hardware—can impact the suitability and performance of this handle. It is the responsibility of the installer to assess these factors prior to installation.

We do not accept liability for issues arising from incorrect installation, misuse, or circumstances beyond our control.

1

- Use the template for reference (NOT TO SCALE) to mark the centre of the 51mm hole on both sides of the door.
- Mark the horizontal centre line for the 25mm latch hole, then mark the centre of the door thickness.
- Drill the 51mm hole from both sides of the door to prevent splintering.
- Drill the 25mm hole into the edge of the door, centred on the thickness, ensuring it is straight and square.

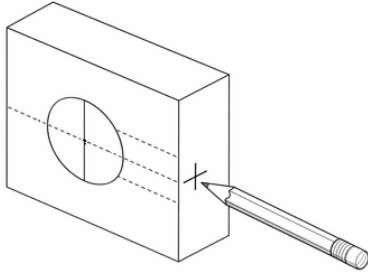

2

- Insert the latch and mark around the faceplate.
- Chisel a recess so the faceplate sits flush with the door edge.
- Insert the latch, making sure the curved side faces the direction the door closes.
- Pre-drill holes and secure with the supplied screws.

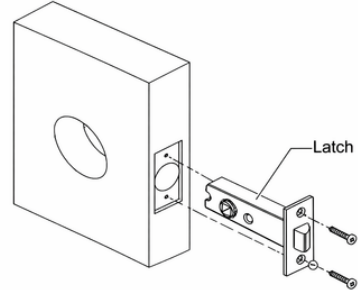

3

- All passage latches are set for inward-opening doors. If your door opens outward, follow the steps below to adjust the latchbolt left or right.



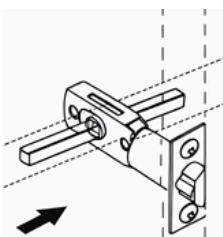

4

- position spindle centrally within the latch



5

- Measure door thickness and select correct mounting screws as per table below.

DOOR THICKNESS	MOUNTING SCREW LENGTH
38-45MM	M4 - 35MM LONG 
32-38MM	M4 - 25MM LONG 

6

- Figure out which side of the door each lever goes on so both move downward when used.
- Remove the rosette caps from the base of each lever.
- Slide each lever onto the spindle.
- Secure the levers together using the provided screws (choose the right length for your door). Insert one screw from each side through the countersunk holes and tighten.
- Put the rosette caps back on each side of lever.

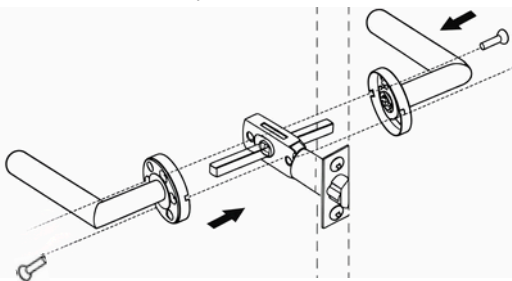

7

- Close the door gently so the latch rests on the jamb and mark the center of the latch. This is where the strike plate will go.
- Drill a 25mm hole in the jamb about 12mm deep.
- Place the strike plate, trace around it, and chisel out the recess so it sits flush.
- Screw the strike plate in place using the 2 supplied screws.

